

Automated ESI Control on Variable-Flow Gradient Nanobore LC-MS

James P. Murphy III¹, Gary A. Valaskovic¹, Karen M. Hahnenberger², David W. Neyer²

¹New Objective Inc, Woburn, MA ²Eksigent Technologies, Livermore, CA

Introduction

Variable-flow or “peak parking” in an LC/MS method allows one to extend the analysis time of a chromatographic peak to provide additional MS/MS analysis for identification of co-eluting compounds or increased integration time for low abundance peptides. Traditionally a series of switching valves and pumps are employed to reduce the flow rate to the LC column at a certain point of interest in a chromatogram. Unfortunately the sudden drop in flow rate will have a dramatic effect on the optimal spray voltage required for electrospray. Depending on the portion of the gradient and the drop in flow, there may be a loss in sensitivity or a failure to spray altogether. An automated control system was designed to alleviate these issues by continually monitoring the electrospray plume and adjusting the required voltage as conditions change. This control system is independent of both the LC and the mass spectrometer.



Figure 1 – LCQ Deca™ (Thermo Electron) equipped with an automated ESI control system. The system is controlled independent of the mass spectrometer by a PC (left). The mass spectrometer and the NanoLC (Eksigent Technologies) are controlled by a second computer (center).

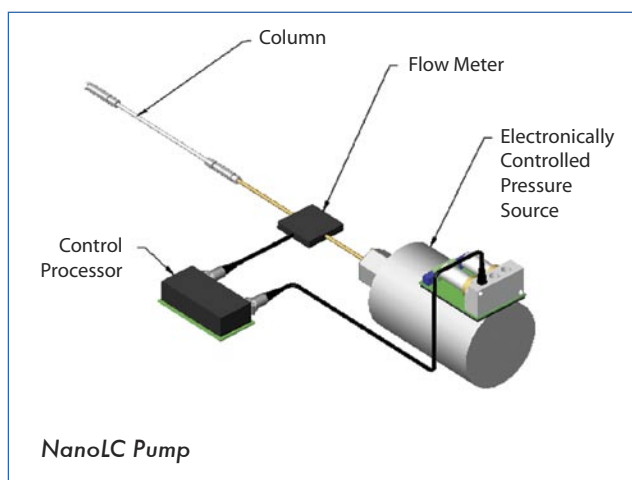
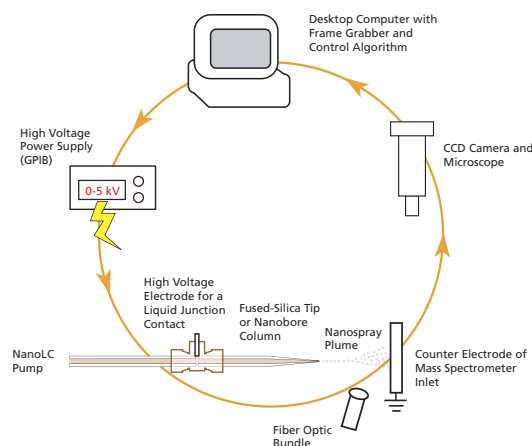

Figure 2 – The NanoLC (Eksigent Technologies) incorporates microfluidic flow control (MFC) technology, which consists of an electronically controlled pressure source, an in-line flow meter, and a control processor. The flow meters continuously measure the actual flow rate of each mobile phase. The information is passed to an embedded processor that controls a rapidly responding, electronically adjusted variable pressure source.

System Components

A PicoView[®] nanospray source (New Objective) was mounted on an LCQ Deca[™] (Thermo Electron) ion trap mass spectrometer. Voltage was provided to the source by a high-voltage power supply (Stanford Research Systems Inc.) controlled by a GPIB interface. A fiber optic bundle connected to a 150W tungsten-halogen illuminator provided intense illumination. A CCD camera-based video microscope, positioned orthogonal to the ESI emitter, fed images into a PC equipped with a frame capture board. An image analysis and high voltage control algorithm was written in the LabVIEW[™] (National Instruments) programming environment. The electrospray voltage was under full control of the host PC, uncoupled from a mass spectrometer.

Figure 3 - Schematic of the spray analysis and orthogonal control system.



Spindle Mode
Pulsed Spray
+Large (5 μm) Drops



Pulsed Cone-Jet
Pulsed Spray
+Small (1 μm) Drops



Stable Cone-Jet



Multi-Jet
Pulsed/Chaotic Spray



Ramified-Jet
Chaotic Spray



Figure 4 - Scattered light images for commonly observed spray modes. The applied voltage is on the upper left hand corner of the image. The emitter was 15 μm and the mobile phase was 50% MeOH, 1% acetic acid pumped at 250 nL/min. the automated control system is designed to achieve a stable-cone jet mode under any condition.

Gradient elution mobile phase was delivered by a NanoLC (Eksigent Technologies). The NanoLC system provides direct control of binary gradients to separation columns at flow rates of 20-1000 nL/min, without the need for flow splitting. A benefit of this actively flow-controlled LC system is the ability to rapidly and accurately lower the separation column flow rate during the gradient profile, providing integrated peak parking without the need for additional switching valves and pumps. This capability allows extended analysis time of a chromatographic peak to provide additional MS/MS analysis for identification of co-eluting compounds or increased integration time for low abundance peptides. A data dependant control signal (via contact closure) provided by the LCQ triggered the pump to lower the flow rate from the typical value of 400 nL/min to 40 nL/min.

Methods

Mass Spectrometer: Thermo Finnigan™ LCQ Deca™

Full scan: 300 – 1500 m/z

μScans: 3

LC: Eksigent NanoLC

Mobile Phase A:

Water / 2% ACN / 0.1% Formic Acid

Mobile Phase B:

ACN / 0.1% Formic Acid

Gradient:

Hold at 0% B for 2 min

Ramp to 30% B over 16 min

Ramp to 60% B over 1 min, hold 5 min

Return to 0% B over 1 min, hold 5 min

Flow rate: 400 nL/min

Peak Parking Flow rate: 40 nL/min

A Peak Parking event was triggered by a contact closure on the LCQ Deca

The contact closure was activated when m/z 837.2 ([M+2H]²⁺ of

Neurotensin) reached the activation threshold of 6x10⁵

Column:

PicoFrit® column 360 μm x 75 μm with a 15 μm tip

5 cm packing bed of POROS® R2, 10 μm, (Applied Biosystems, Inc.)

Test Standard:

1 μL injections of a 100 fmol/peptide/μL solution composed of

Angiotensin I, Neurotensin, Bradykinin, Angiotensin II, Oxytocin

Results: Fixed ESI potential

The fixed potential optimized for a flow of 400 nL/min becomes less favorable as the peak parking event occurs at a flow of to 40 nL/min. The over potential results in a multi-jet spray mode and creates a corona discharge at the tip of the emitter. This produces mass spectra of low S/N. Notice the [M+3H]³⁺ ion of Neurotensin cannot be distinguished among the background.

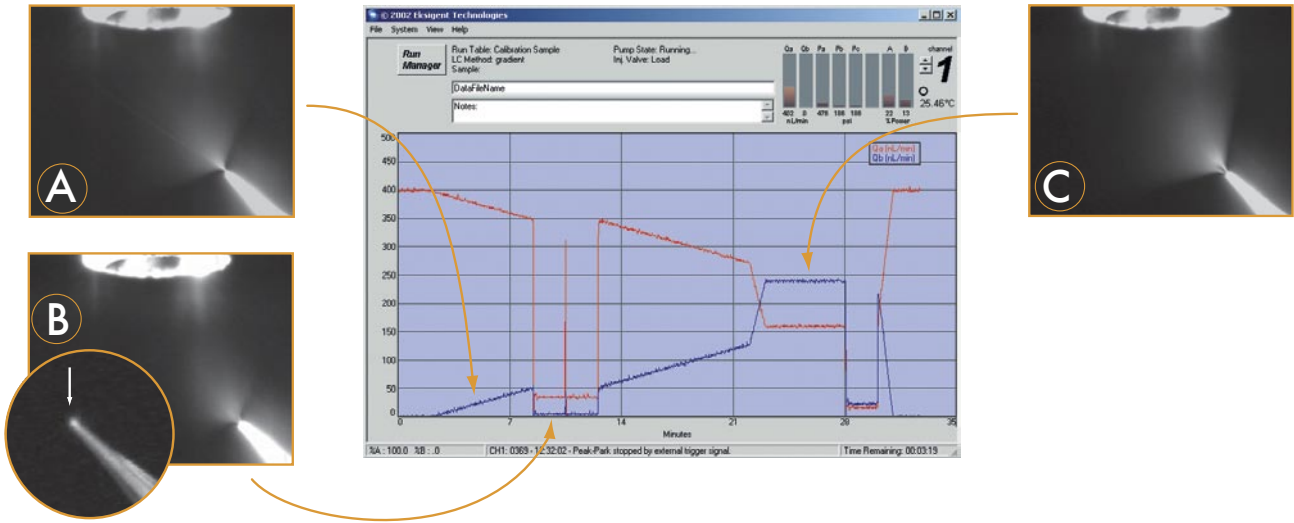

Figure 5 – Gradient profile expressed in terms of flow rate (nL/min). The different spray modes shown are the result of a fixed nanospray potential of 2340 V across the entire gradient. (A) A stable cone jet spray mode is formed at 7% B (375 nL/min A, 25 nL/min B) with the fixed potential. (B) During a peak-parking event the flow drops to 1/10 of its original value to 40 nL/min and multi-jet spray mode is formed. In the absence of illumination (see inset) a glow can be observed from the tip indicating the presence of a corona discharge. (C) During the column flushing at 60% B (160 nL/min A, 240 nL/min B) a multi-jet spray mode is again observed as the viscosity of the mobile phase decreases.

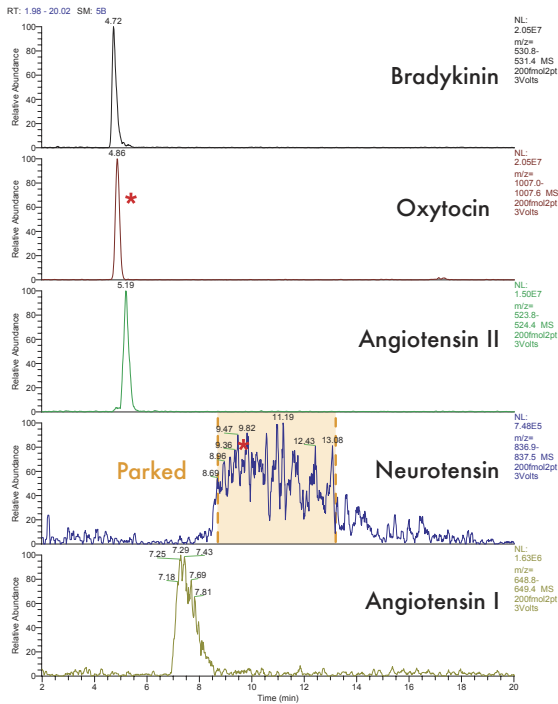

Figure 6 – Reconstructed ion chromatograms of the five peptide mixture with a fixed nanospray potential. Peak parking at 40 nL/min was triggered by the mass spectrometer. The extended ion chromatogram shows that the acquisition was extended by approximately 8x.

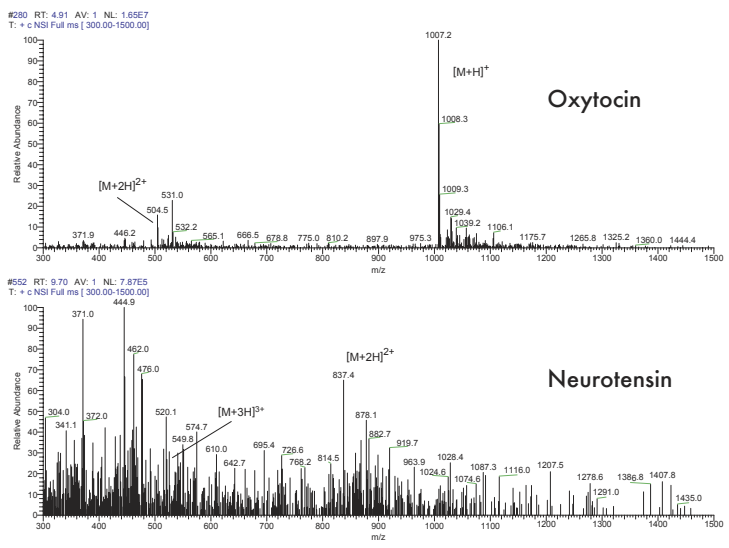

Figure 7 - Mass spectra of Oxytocin and Neurotensin highlighted by the red asterisk.

Results: Automated ESI

The automated control system monitors the electrospray plume orthogonal to the mass spectrometer. The system characterizes the spray and determines the spray mode. A control algorithm then adjusts the applied voltage so a desirable spray mode is obtained.

The nanospray potential is lowered upon discovery of either a multi-jet or a ramified-jet mode, raised with the discovery of a spindle or a pulsed cone-jet and is held constant for the stable cone-jet mode. In this particular case the flow is lowered by a factor of ten during peak parking and must be accompanied by a lower potential. As the flow drops, multi-jet modes are observed by the software (Figure 8) and the potential is lowered until a stable cone-jet mode is observed (see Figure 9C).



Figure 8 - Spray analysis of the multi-jet mode by the automated control system software

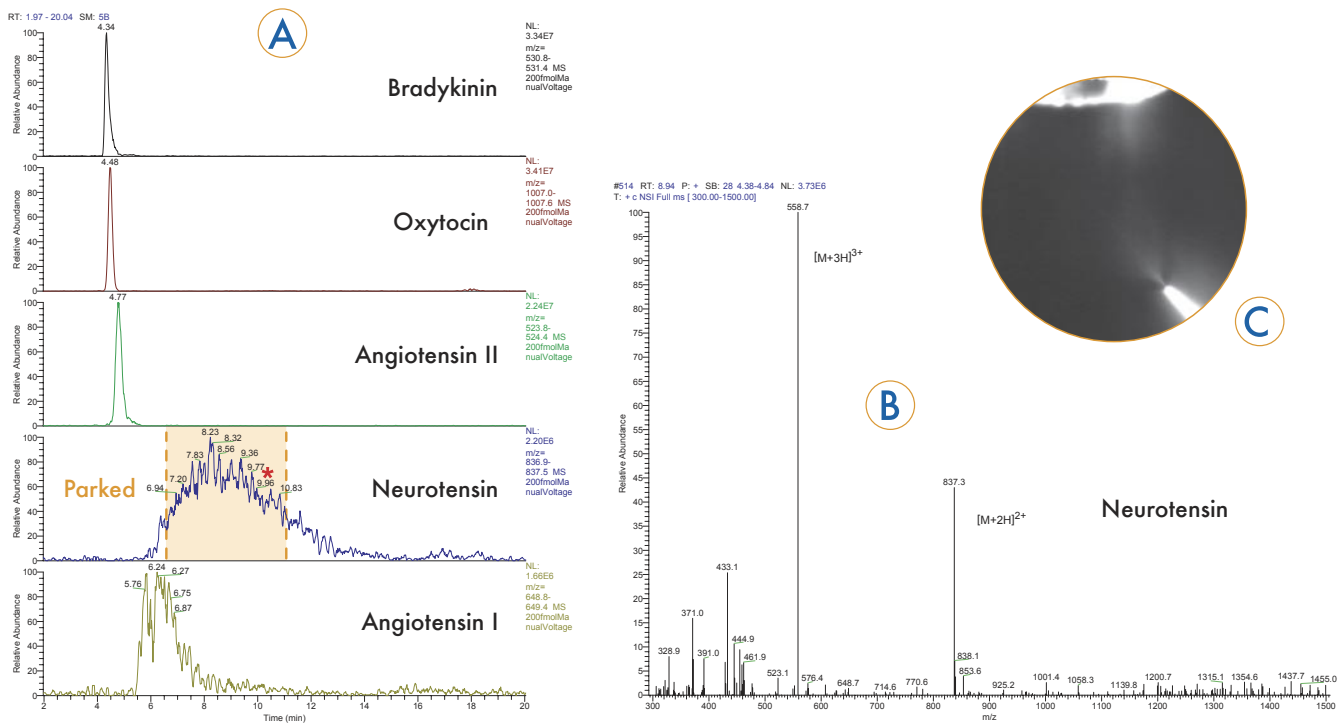
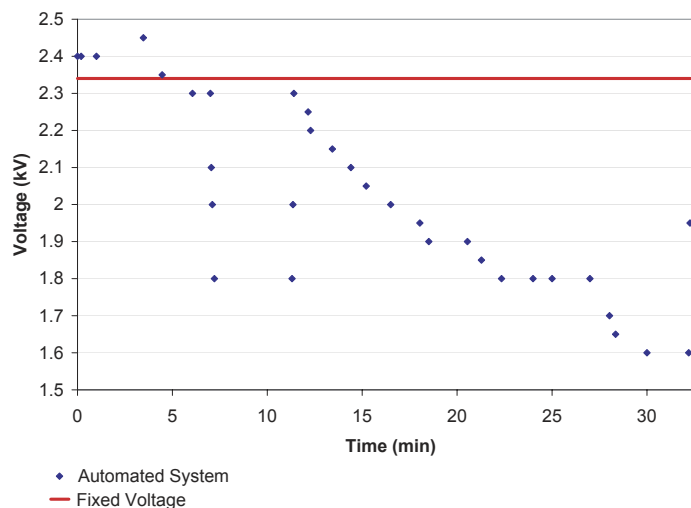

Figure 9 - (A) Reconstructed ion chromatograms of the five peptide mixture with a fixed nanospray potential. Peak parking at 40 nL/min was triggered by the mass spectrometer. (B) Neurotensin mass spectrum highlighted by the red asterisk. (C) A stable cone-jet mode observed with the automated control system during a peak parking event (40 nL/min).

Figure 10 (right) – Nanospray potential under a fixed condition (red line) and under the automated control system (blue dots) across the gradient.



Conclusions:

- Rapidly dropping the flow during an LC gradient in a peak-parking experiment can extend the detection time of an eluting peak up to 8 times allowing sufficient time to collect data in MS/MS mode.
- Under a fixed nanospray potential, a change in flow can alter the physical forms referred to as spray modes emitting from a nanospray emitter from an ideal mode such as a cone-jet mode (forming droplets with a high charge-to-mass ratio) to a less desirable mode such as a multi-jet mode.
- An excess potential during a peak-parking experiment can also result in a corona discharge at the tip of the emitter producing mass spectra with poor S/N.
- An automated system described here successfully controls the nanospray potential providing the most optimal spray during a peak parking experiment and across a gradient resulting in mass spectra with superior S/N.

Originally presented at the 52nd Conference of the American Society of Mass Spectrometry, 2004

© 2004 New Objective, Inc. All rights reserved.
All trademarks and registered trademarks are properties of their respective companies.